

NAVIGATION AND VESSEL INSPECTION CIRCULAR NO. 4 86  
*Electronic Version for Distribution Via the World Wide Web*

Subj: HYDRAULIC RELEASE UNITS FOR LIFERAFTS, LIFE FLOATS, AND BUOYANT APPARATUS, AND ALTERNATE FLOAT-FREE ARRANGEMENTS

1. PURPOSE. This Circular summarizes the requirements for installing, testing, and maintaining Coast Guard approved hydraulic release units used with liferafts, life floats, and buoyant apparatus. Alternate float-free arrangements not requiring hydraulic releases are also discussed.
2. DIRECTIVES AFFECTED. Navigation and Vessel Inspection Circular 7-69 is canceled, along with Changes 1, 2, and 3.
3. DISCUSSION.
  - a. General Description. Hydraulic release units (also referred to as hydrostatic release units or HRUs) are mechanical devices used as -links in the lashings securing liferafts, life floats or buoyant apparatus to the deck of a vessel. If a vessel sinks before the crew can manually launch the equipment, the pressure of the water operating on the HRU automatically separates it into two parts. This action, at a depth of between 5 and 15 feet, disconnects the lashing and permits the unrestrained liferaft, life float or buoyant apparatus to rise to the surface by its own buoyancy.
  - b. Alternate Float-Free Arrangements. An HRU is not necessary for satisfactory float-free installation of an inflatable liferaft, life float, or buoyant apparatus. Enclosure (1) shows the installation of a float-free inflatable liferaft in a crib made of removable loose-fitting stanchions and bars. The height of the enclosing stanchions will depend on the location of the raft on deck and its exposure to boarding seas. Enclosure (2) shows a stowage rack in gimbals for preventing a liferaft from being trapped if the vessel should capsize as it sinks. Apart from the details of the stowage rack, its location on deck must receive careful consideration, especially on vessels with low freeboards where green water washing over the deck could result in the loss of the raft.
  - c. Navy/Coast Guard HRUs. The first Coast Guard approved HRUs evolved from designs manufactured to a U.S. Navy specification, MIL-R-15041. Three of these stamped-metal devices received approval, although the "Arrow" unit is no longer in production. Enclosure (3) includes details of these first HRUs, a table of their operating features, and details of the gripes for restraining the lifesaving device.
    - (1) The Raftgo Model C is produced by Raftgo Hendry Co. (formerly C.J. Hendry Co.) under Coast Guard approval numbers 160.062/1/0 through 160.062/1/4. Raftgo Model C releases may be used to secure a single liferaft, life float, or buoyant apparatus, or multiple devices.

- (2) The Arrow Model 404 was produced by Arrow Manufacturing Co. under Coast Guard approvals 160.062/210 and 160.062/2/1. The Switlik Model S-880 is essentially identical to the Arrow HRU, and is produced by Switlik Parachute Co. under approval number 160.062/3/0. Although these units are marked for a capacity of up to 3750 lbs., the gripe spring arrangement will deform under a buoyant load of around 1000 lbs. Therefore, Arrow and Switlik releases are approved for single unit installation only. They must not be used to secure more than one liferaft, life float, or buoyant apparatus, or the buoyant load may deform the gripe spring arrangement.
- d. Painter-Securing HRUs. In Europe, painter-securing HRUs perform the three-part function of (1) a full-strength securing point for the inboard end of the sea painter; (2) an attachment point for the float-free weak link on the same end of the sea painter; and (3) a release point for one end of the strap restraining the lifesaving equipment. In contrast, the Navy/Coast Guard style devices shown on Enclosure (3) perform only the third of these three functions. Enclosure (4) shows how the painter-securing HRUs differ from the Navy/Coast Guard type. Unproved versions of these devices are available in the U.S. for uninspected vessels, and there may soon be Coast Guard approved versions that can be used on inspected vessels.
- e. Installation of Navy/Coast Guard HRUs. Enclosure (5) shows the proper installation of any one of the three HRUs discussed under paragraph 3-c. Variations of this arrangement may be necessary to meet the specific features of different vessels, but all installations should conform to the following:
- (1) An HRU and its gripe assembly require a preload tension applied by a turnbuckle so that any movement of the HRU plunger, by either water pressure or manual force, will separate the two halves of the device and free the gripe.
  - (2) The correct installation of an HRU keeps it solely under tension loading with the device suspended between its end fittings. The HRU must not be subjected to side loads or bending loads resulting from contact with the lifesaving device or any other object. An HRU may fail to operate if it is forced into bending or contact with a liferaft container as shown in Enclosure (6).
  - (3) The release button on the end of the plunger must face away from the raft or other device on the side from which it is approached, so that the release plunger is accessible for manual operation.
  - (4) The sea painter is secured to a float-free weak link which is in turn shackled to the deck or strong point on the vessel. An inflatable liferaft comes equipped with its own weak link. The weak link for a life float or buoyant apparatus must be certified to Coast Guard requirements --46 CFR 160.073-- as indicated on its identification tag. Note that the sea painter is not connected to the Navy/Coast Guard style HRU in any way.
  - (5) The gripe assembly can be released by slackening the turnbuckle or by pushing in on the release plunger. If the lifesaving device is to be moved to a launching station, the painter should be led to the station directly in a straight line, over any

obstructions. If this cannot be done, the painter and weak link should be disconnected and rescued at an appropriate strong point near the launching station.

- (f) Installation of painter-Securing HRUs. Enclosure (7) shows the correct installation of a painter-securing HRU. Variations may be necessary to account for design differences, or to overcome specific installation problems on a particular vessel, but all installations should conform to the following:
- (1) painter-securing HRUs need to have a pelican hook in the gripe arrangement to provide for manual release. The pelican hook must be located where it is readily accessible for manual release. A special tool provided with the HRU will also open it, but this tool is intended for maintenance and will not normally be stowed in a place convenient to the HRU.
  - (2) When they obtain Coast Guard approval, painter-securing HRUs will probably be equipped with gripe-tensioning springs. In any case, the gripe should be snug when the hook is closed and the gripe is assembled to the release.
  - (3) The release is secured to the deck or to a bracket on a liferaft cradle intended for this purpose. Like the Navy/Coast Guard release, the painter-securing HRU must not contact a raft container or any other object that would impart a side load or bending load.
  - (4) The sea painter is attached directly to the painter-securing 'HRU by a link or shackle. Any weak link supplied with an inflatable liferaft on the inboard end of its painter should be removed and discarded
  - (5) In place of the discarded weak link discussed in Subparagraph 3-f(4), the HRU will have its own weak link of 500 lbs. breaking strength. One end of the weak link is attached to the deck either directly or through the part of the HRU attached to the deck. The other end is attached to the link or shackle at the end of the painter. The link or shackle is attached to the HRU so that the weak link is not a load carrying part of the painter system until the release opens. Note especially that for inflatable liferafts the weak link used should be the one supplied with the release and of the 500 lb. strength as required for an inflatable liferaft. For life floats and buoyant apparatus, the weak link must be one certified under 46 CFR 160.073 of the proper strength, and of a length that will work properly with the release.
  - (6) The gripe assembly can be released by opening the pelican hook, or using the special tool to open the HRU. If the raft is to be moved to a launching station, the painter should be led to it in a straight line, over any obstructions. A raft using a painter-securing 'HRU should not normally be installed in a place where there is no direct access to a launching station, since it is not possible to move the weak link and painter to a new securing point, without having the special tool that opens the HRU.
- g. On-board maintenance of hydraulic releases. HRUs must be maintained in good condition in order to work properly. The following should be noted:

- (1) HRUs must not be sandblasted, cleaned by chemicals other than fresh water, and must not be painted on board.
  - (2) If an HRU gets dirty or salt-covered, it should be cleaned by a wash down with clean fresh water (preferably warm).
  - (3) No attempt should be made to repair an HRU on board. If it needs repair, it must be sent to an authorized repair and testing facility (see "Equipment Lists", Coast Guard publication COMDTINST M 16714.3 series, under "160.062 Hydraulic Release.")
  - (4) Parts of one HRU should not be interchanged with another. The mating surfaces may vary to the degree that one unit assembled from the parts of different units will not reliably work at the design depth. The parts should be used together as they come from the manufacturer or authorized testing facility.
- (h) Repair and testing of hydraulic releases. HRUs must be tested annually by an authorized testing facility. If an HRU needs to be repaired, the repair must be done by an authorized repair and testing facility. Not all testing facilities are authorized to do repairs.
- (1) Testing facilities should attach a tag to all Arrow and Switlik devices stating that they are for single-raft installation only, if the devices are not already so marked.
  - (2) The Coast Guard may soon approve a disposable type, painter-securing HRU. This device is intended to be replaced rather than periodically tested and repaired. If this device is approved, it will include a means for marking the expiration date by which the device must be replaced.

4. ACTION.

- a. Inspected vessels must comply with the guidance in this Circular in order for their HRU installations to meet Coast Guard regulations.
- b. Uninspected vessels using HRUs are urged to comply with the guidance in this Circular in order for their equipment to perform as intended.

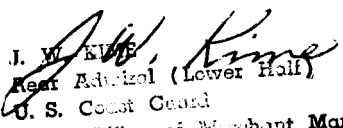
  
J. M. KIME  
Rear Admiral (Lower Half)  
U. S. Coast Guard  
Chief, Office of Merchant Marine Safety

- End:
- (1) Float-free Crib of Removable Stanchions and Bars.
  - (2) Stowage Rack in Gimbals.
  - (3) Navy/Coast Guard Hydraulic Release Units
  - (4) Painter-securing Hydraulic Release Units
  - (5) Installation of Navy/Coast Guard Hydraulic Release Units
  - (6) Incorrect Contact of HRU With Lifesaving Device.
  - (7) Installation of Painter-Securing Hydraulic Release Units

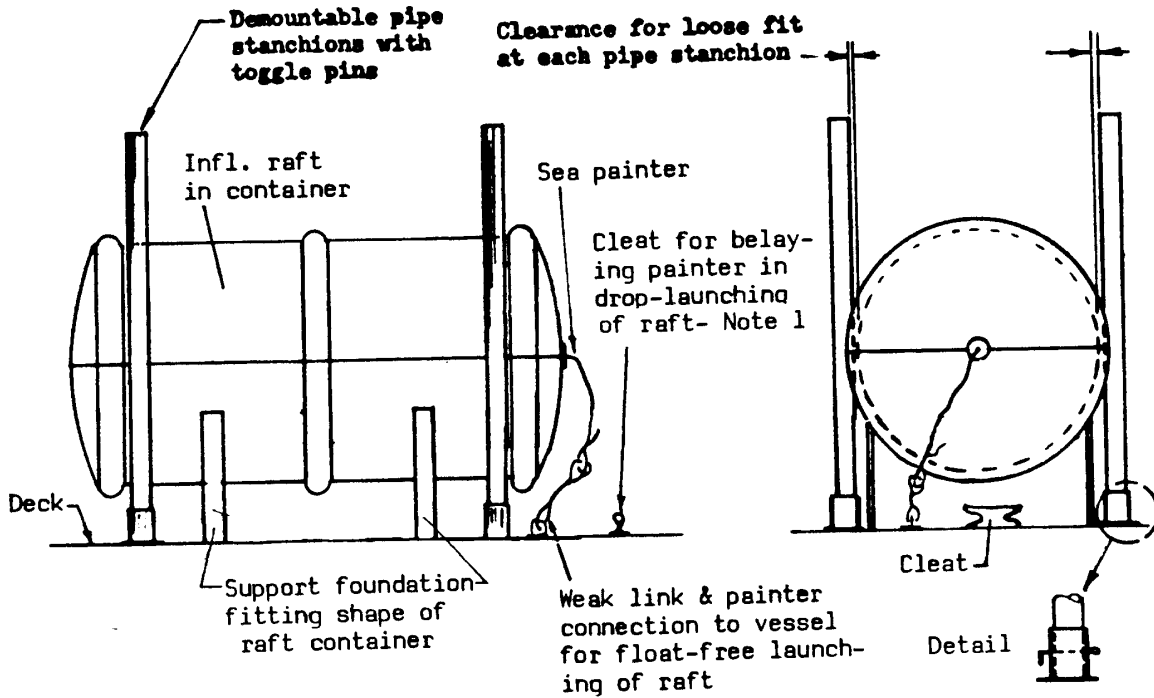

Notes

- 1- Drop-launching of the raft requires a bypassing of the weak link so that the vessel will keep a strong hold on the raft as it floats alongside for the embarkation of personnel. A few feet of painter pulled out of the raft container and made fast to the cleat will bypass the weak link.

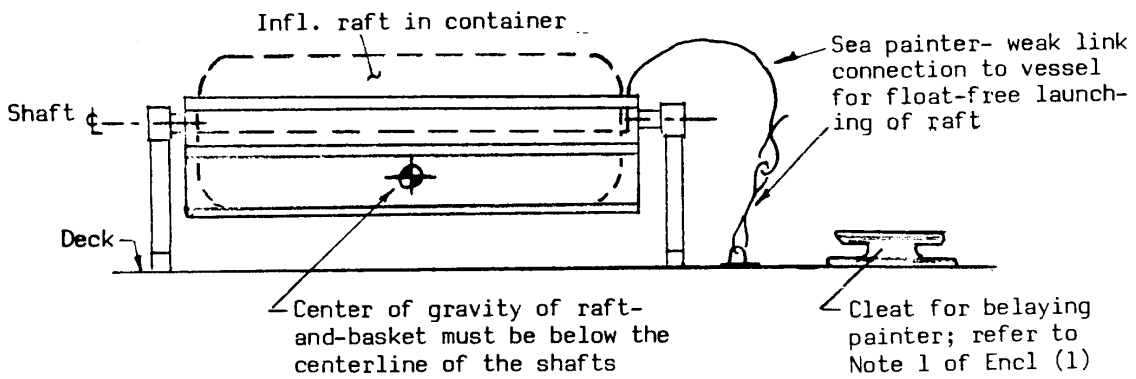
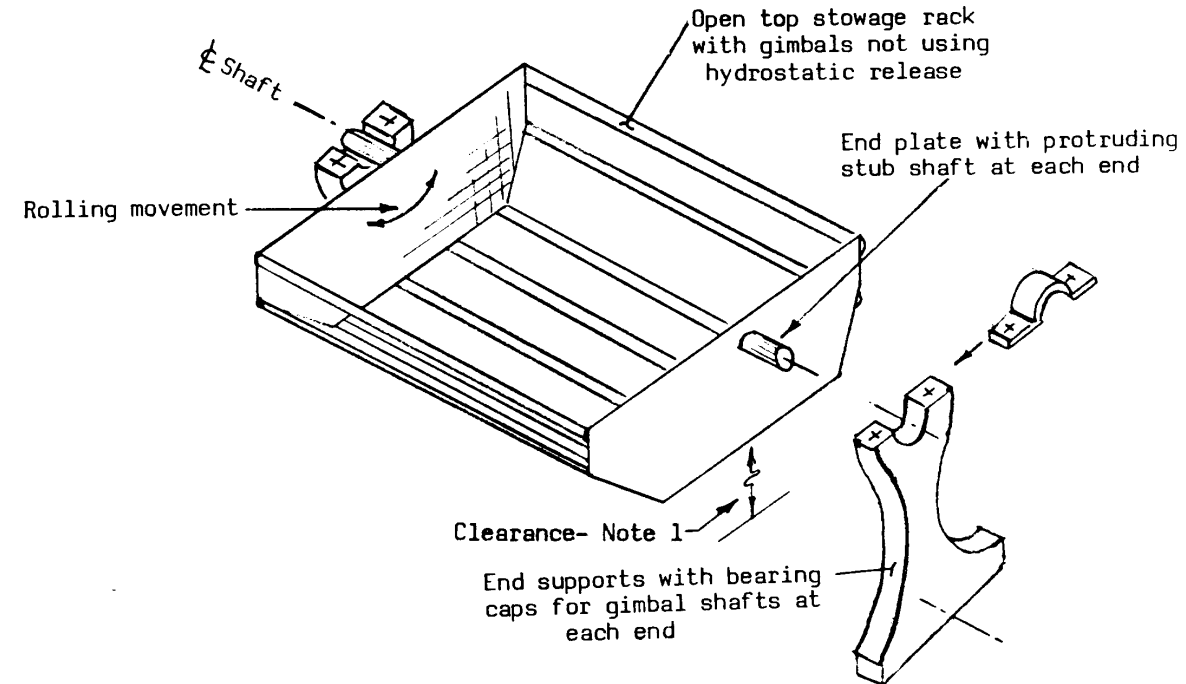

Notes

- 1- Installation requires sufficient clearance of stowage rack above deck to accommodate 90-degree roll of vessel.

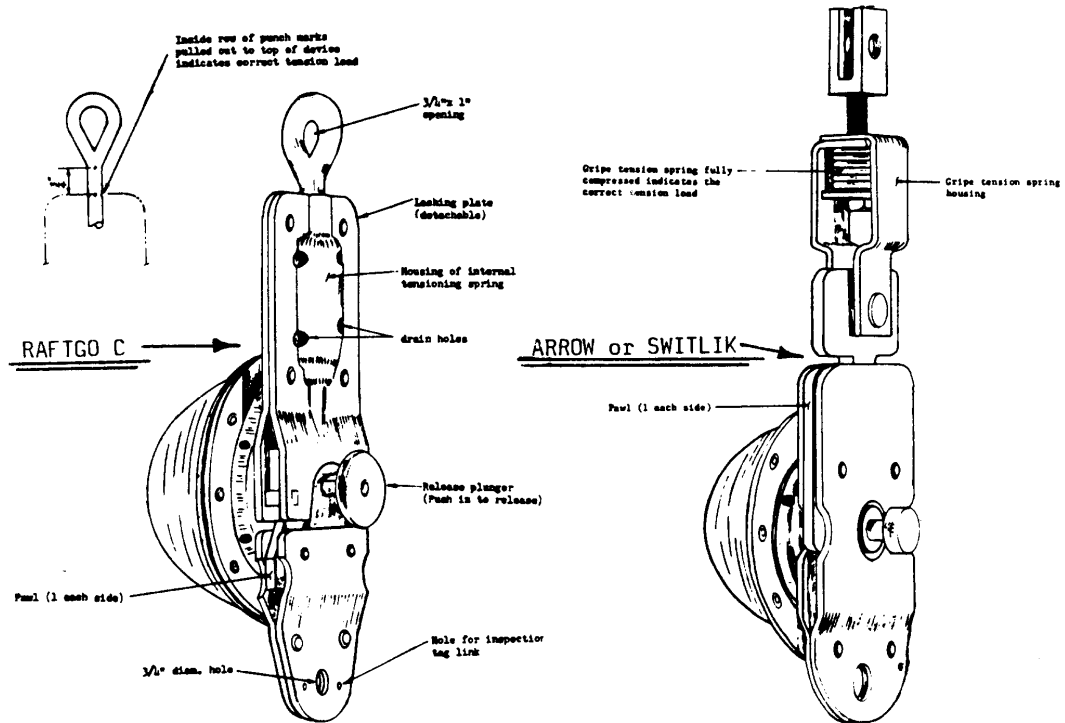

Mfr. Iden.	Current Appr. Nos.	Acceptable Buoyant Loads	Gripe Spring Tension	Comments
Raftgo-Model C	160.062/1/4	200 lbs. min. 3,750 lbs. max.	Internal spring-producing 85 lbs. tension @ 3/4" stretch as indicated by punch marks on eye bolt	Acceptable for single-raft & multiple-raft installations; 3,750-lb. max. limit for a multiple raft installation
Switlik-Model S-800	160.062/3/0	200 lbs. min. 800 lbs. max.	External compression spring; full compr. to 1/2" height produces 40-45 lbs. of gripe tension	For infl. rafts use is restricted to single-unit installations, 25-person max. size
Arrow-Model 404	160.062/2/1	200 lbs. min. 800 lbs. max.	External compression spring when fully compressed produces approx. 62 lbs. of tension	For infl. rafts use is restricted to single-unit installations, 25-person max. size

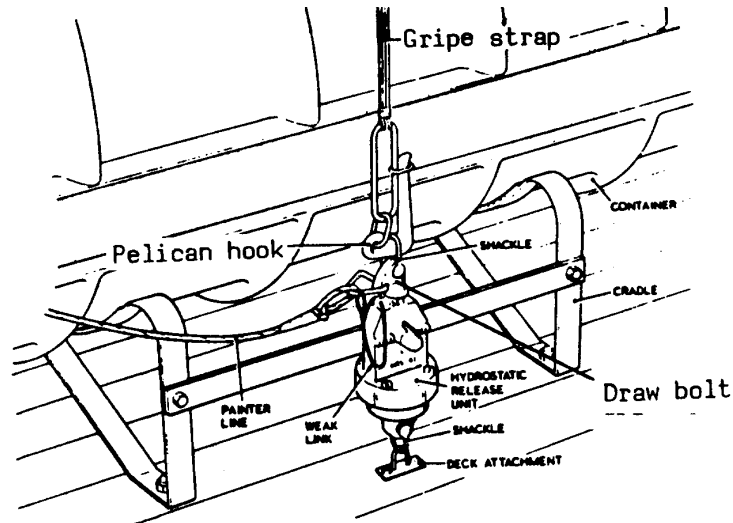

Figure 1 Typical Installation of Painter-securing HRU

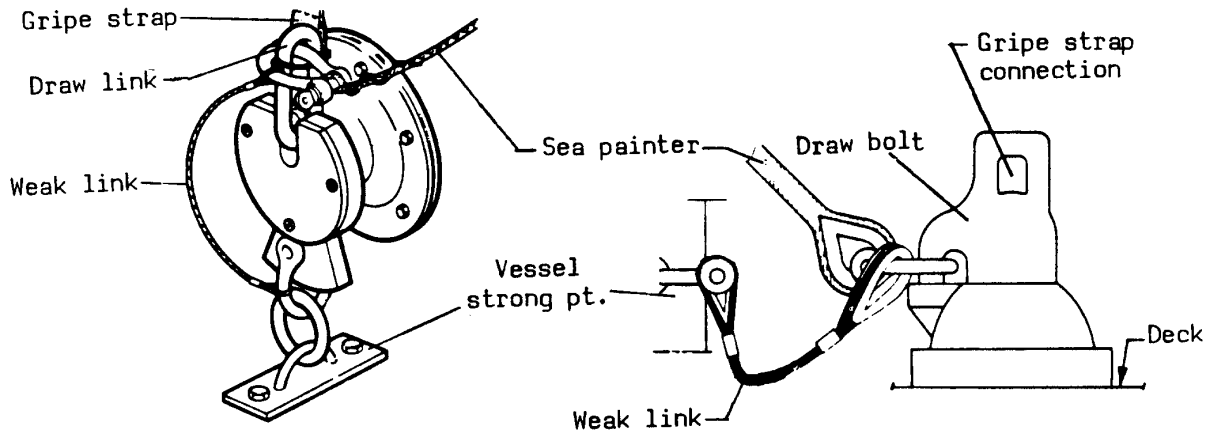

Figure 2

Figure 3

Notes

1- The foreign raft installation of Fig.1 lacks the cleat found in a U.S. installation under 46 CFR 160.051-7(b)(8) requirements. Drop launching a raft from this arrangement with the cleat absent has the full length of the sea painter (at full strength) pulling on the shackle connecting to the draw bolt. By this method there is no necessity to bypass the weak link in order to maintain the full-strength connection of the painter by the steps explained in Note 1 of Encl(1). But the absence of the cleat and the full length of painter may add to the difficulty of keeping the raft alongside for embarking personnel.

1- Installations of the HRUs shown in Figs.1 and 2 have them suspended in tension similarly to the U.S. designs shown by Encl(3). The bell-shaped HRU of Fig.3 is mounted on deck and requires a lever-tool for removal of its draw bolt.



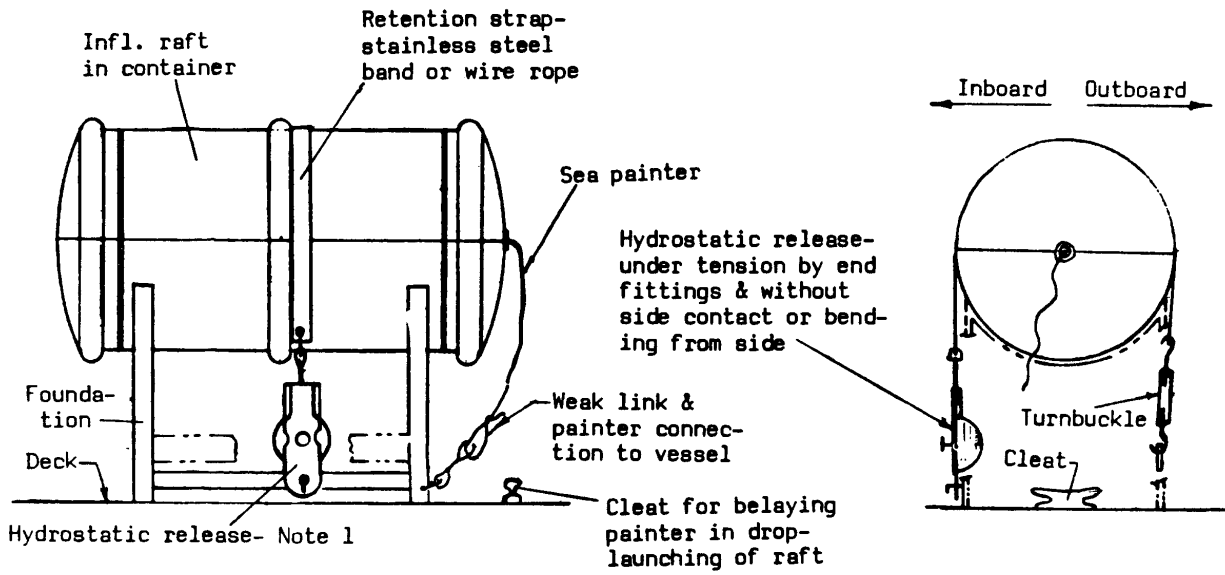

Notes

- 1- A pelican or other slip hook connecting the HRU to the retention strap would be an acceptable addition to the above arrangement.

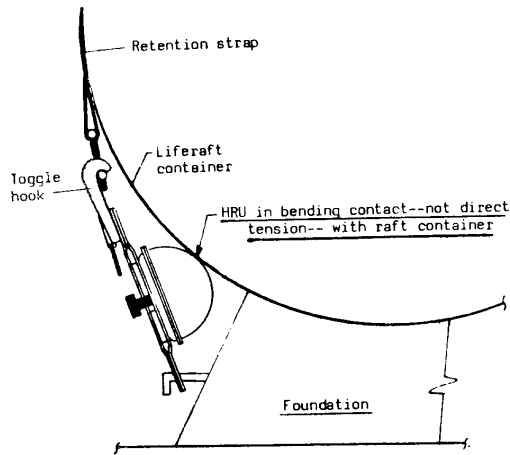

**WRONG!**

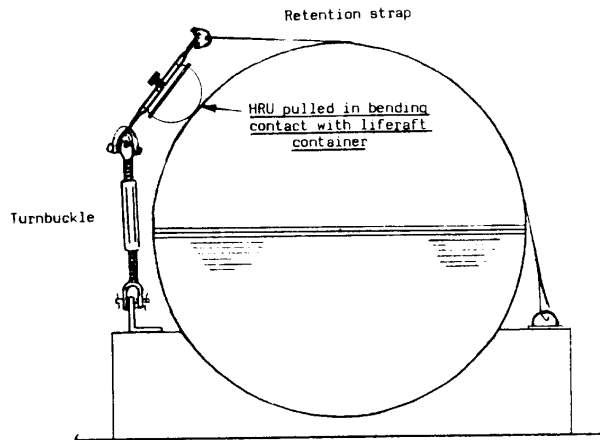

**WRONG!**

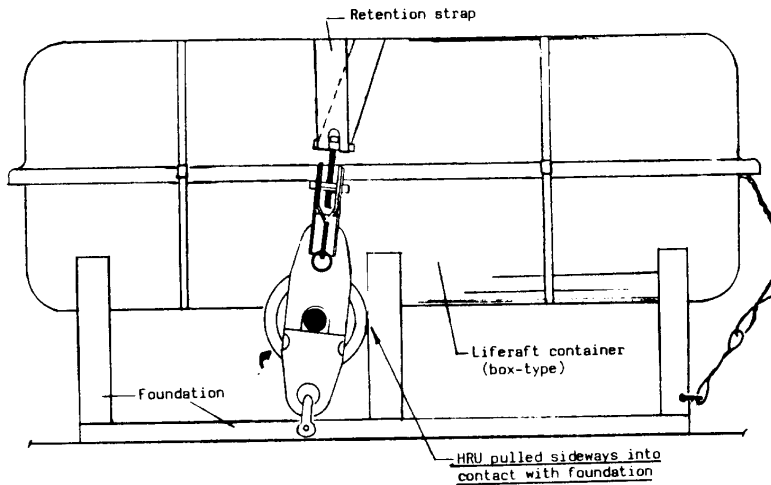

**WRONG!**

Notes

- 1- Although each of the above HRUs is in tension, the bending induced in them from contact with lateral surfaces will bind their internal parts and make the HRUs inoperative.

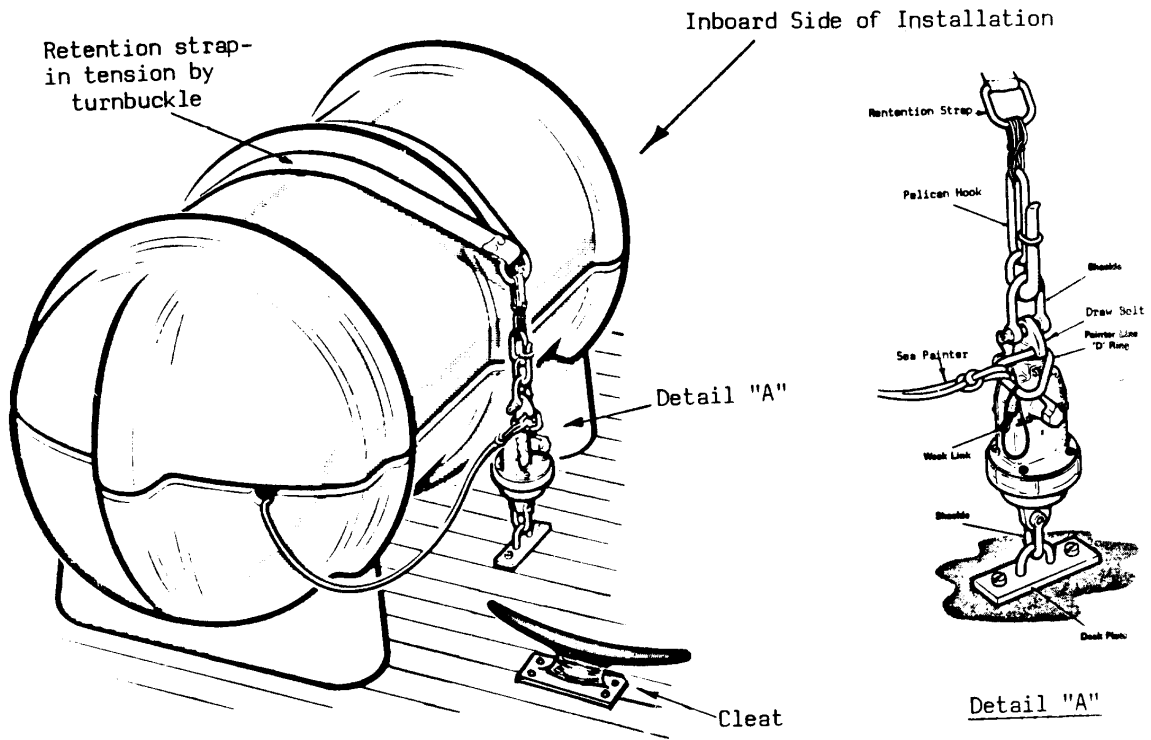

Notes

- 1- Cleat required for compliance with 46 CFR 160.051-7(b)(8) and for belaying painter when keeping raft alongside vessel for boarding after drop-launching.
- 2- The correct installation of this painter-securing HRU has it suspended in tension by the end fittings and without contact with lateral surfaces.